

# MT5/MT4 SERIES

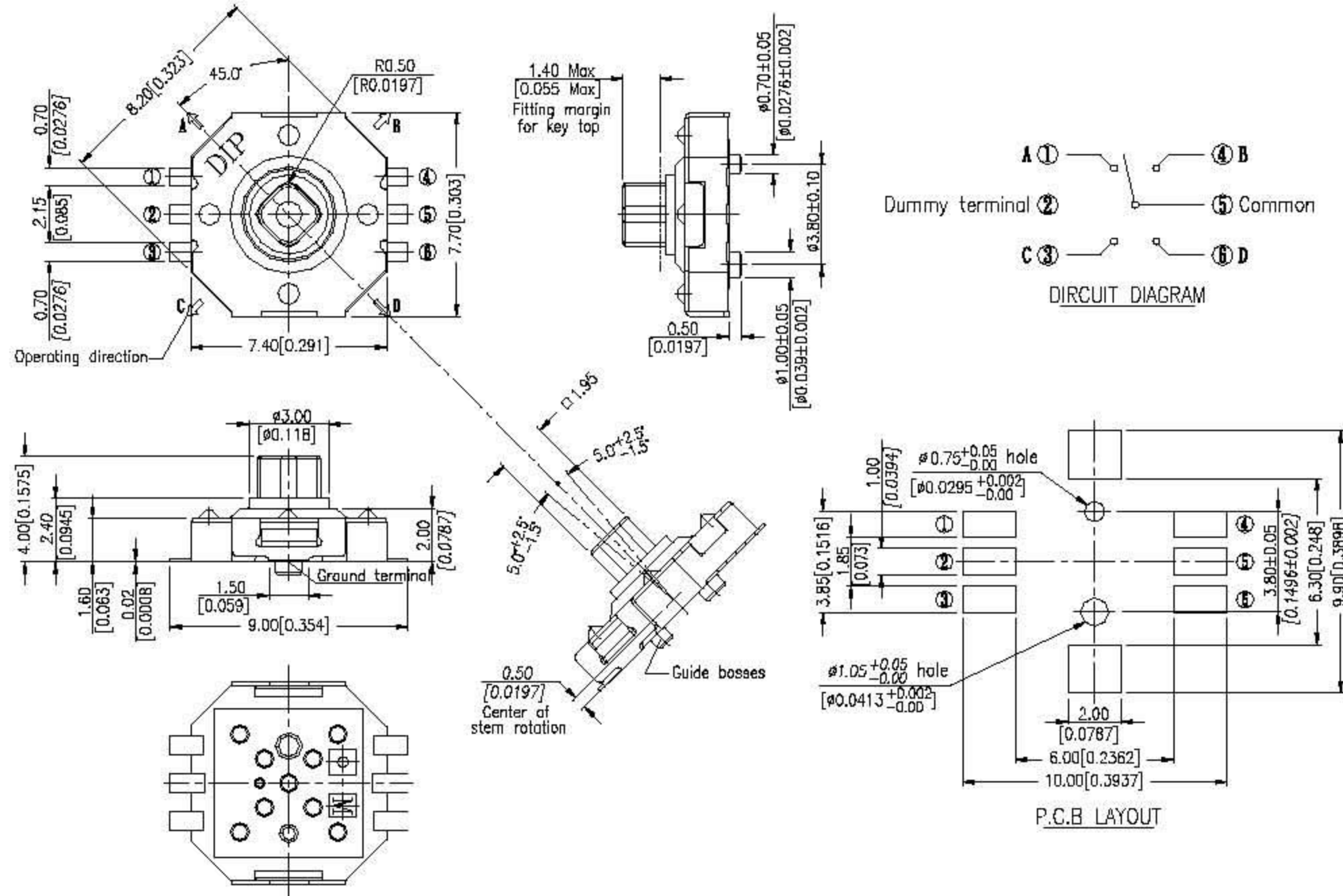

## DIMENSIONS

### MT4-F



General Tolerance : ±0.2mm

### MT5-F

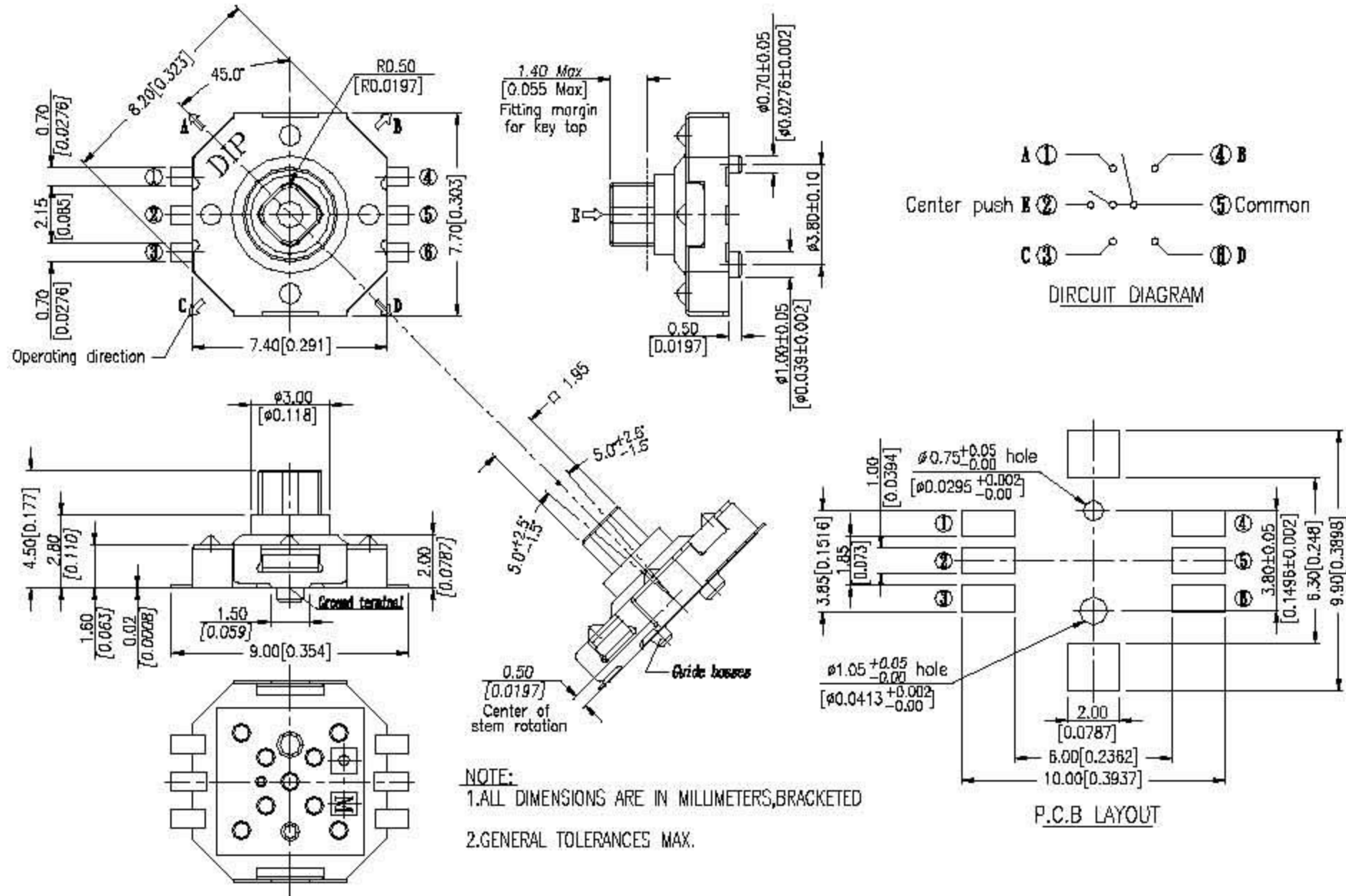

General Tolerance : ±0.2mm

### MT5-L

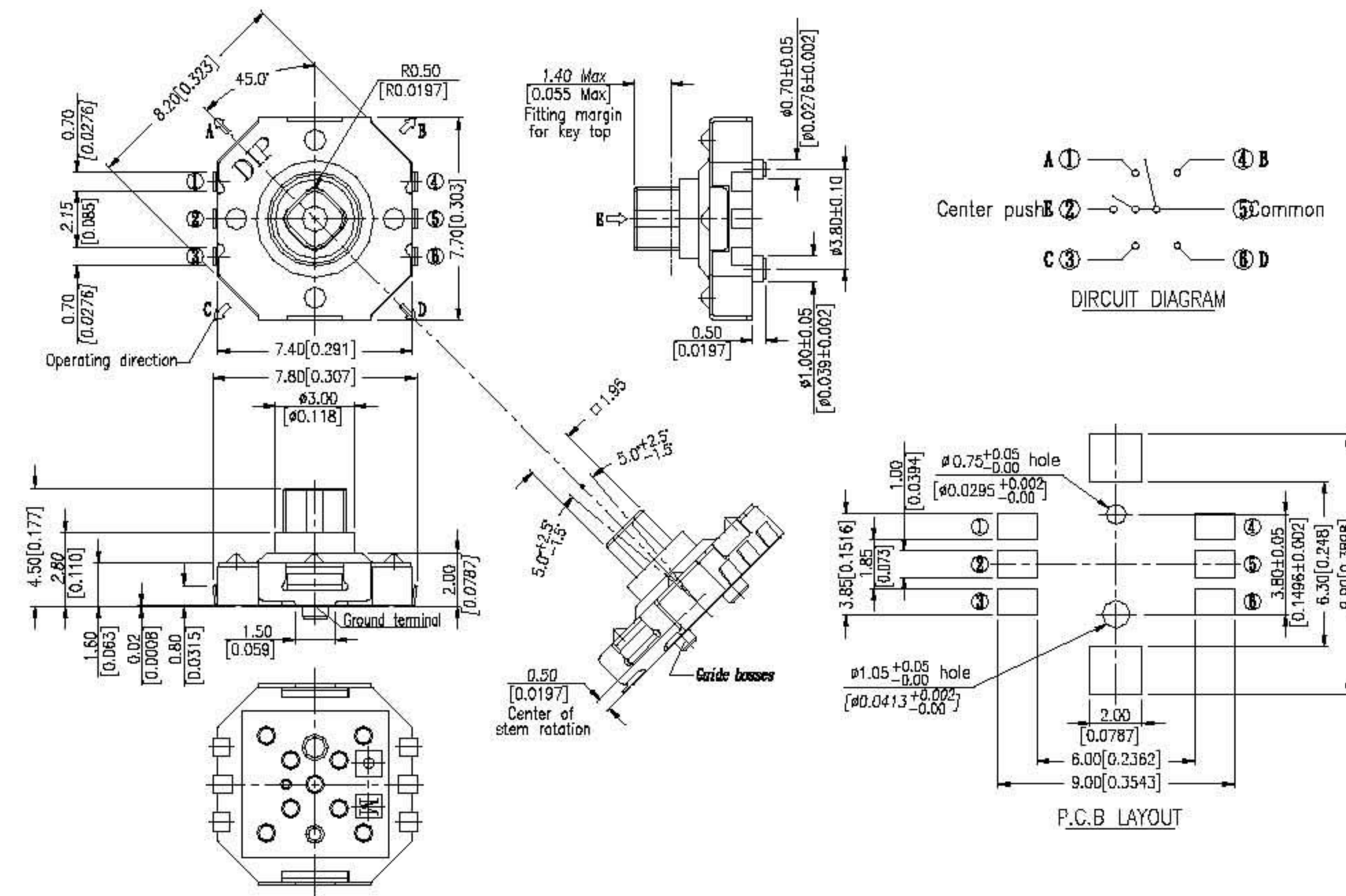

General Tolerance : ±0.2mm

## HOW TO ORDER

M T □ - □ □ - □ - □

Package :  
T/R = Tape & Reel

Soldering :  
V = Lead Free Solderable

L = With J Bend Terminal  
F = With Flat Terminal

□ = 4.5    // //  
1= 5.0    // // (Only 5 Directions)  
2= 4.0    // // (Only 5 Directions)

5 = 5 Directions  
4 = 4 Directions

## SPECIFICATION

### △MECHANICAL

Operation Force: 4-direction: 160gf  
Center push: 320gf  
Stroke: 4- direction: 5°+2.5°/-1.5° mm  
Center push: 0.25+0.1/-0.2 mm  
Operation Temperature Range: -25°C to +85°

### △ELECTRICAL

Electrical Life: 100,000 cycles  
Rating: 50mA, 12VDC  
Contact Resistance: 100mΩ max.  
Insulation Resistance: 100MΩ min. at 100VDC  
Dielectric Strength: 250VAC/1 minute  
Contact Arrangement: 1 pole 1 throw

## MATERIAL

△BASE: UL94V-0 Nylon High-Temp. Thermoplastic  
Color: Black

△COVER : Nickel silver

△CENTER STEM: Nylon High-Temp Thermoplastic  
5Directions Color: Black  
4Directions Color: Brown

△FOUR WAY STEM: Nylon High-Temp Thermoplastic

△CONTACT : Stainless with silver cladding

△TERMINAL: Brass with silver plated

## SOLDERING PROCESSES

△Hand Soldering : Use a soldering iron of 30 watts,  
controlled at 350°C approximately  
5 seconds while applying

△Reflow soldering : When applying reflow soldering, the  
peak temperature or the reflow over  
should be set to 260°C max

△Temperature Profile:

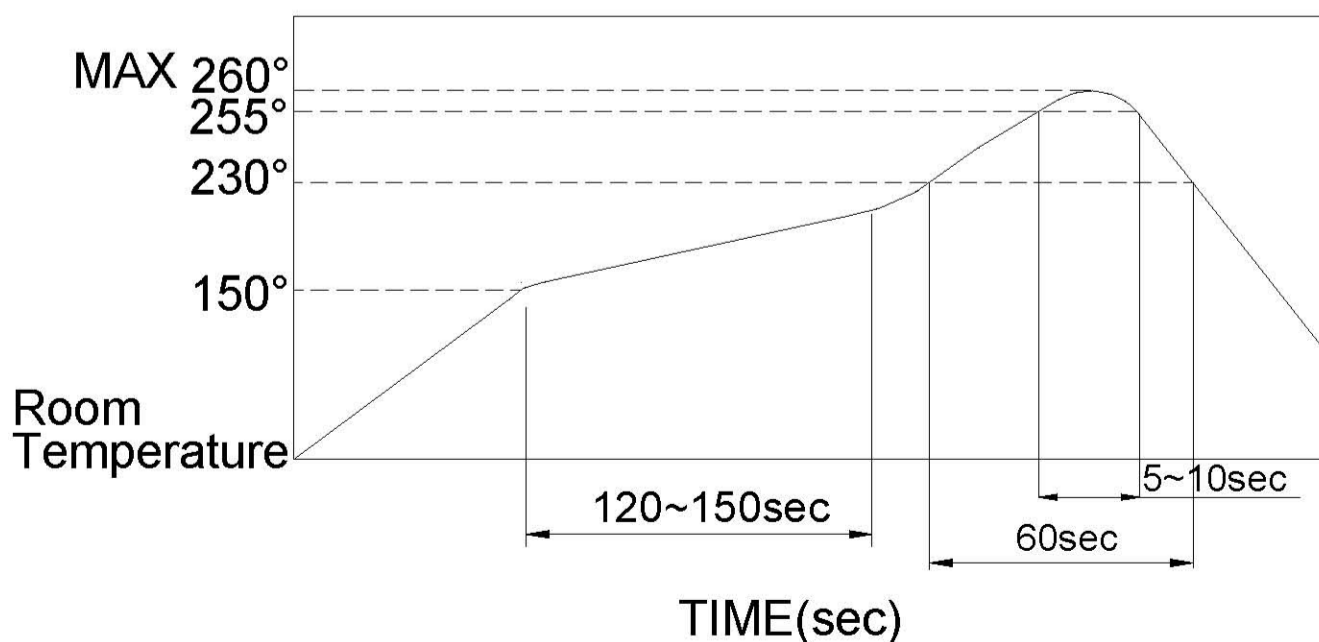

# PACKING

Part Number	Number Per Tube	Number Per Reel
MT4	-	850
MT5	-	850

## MT5 REEL

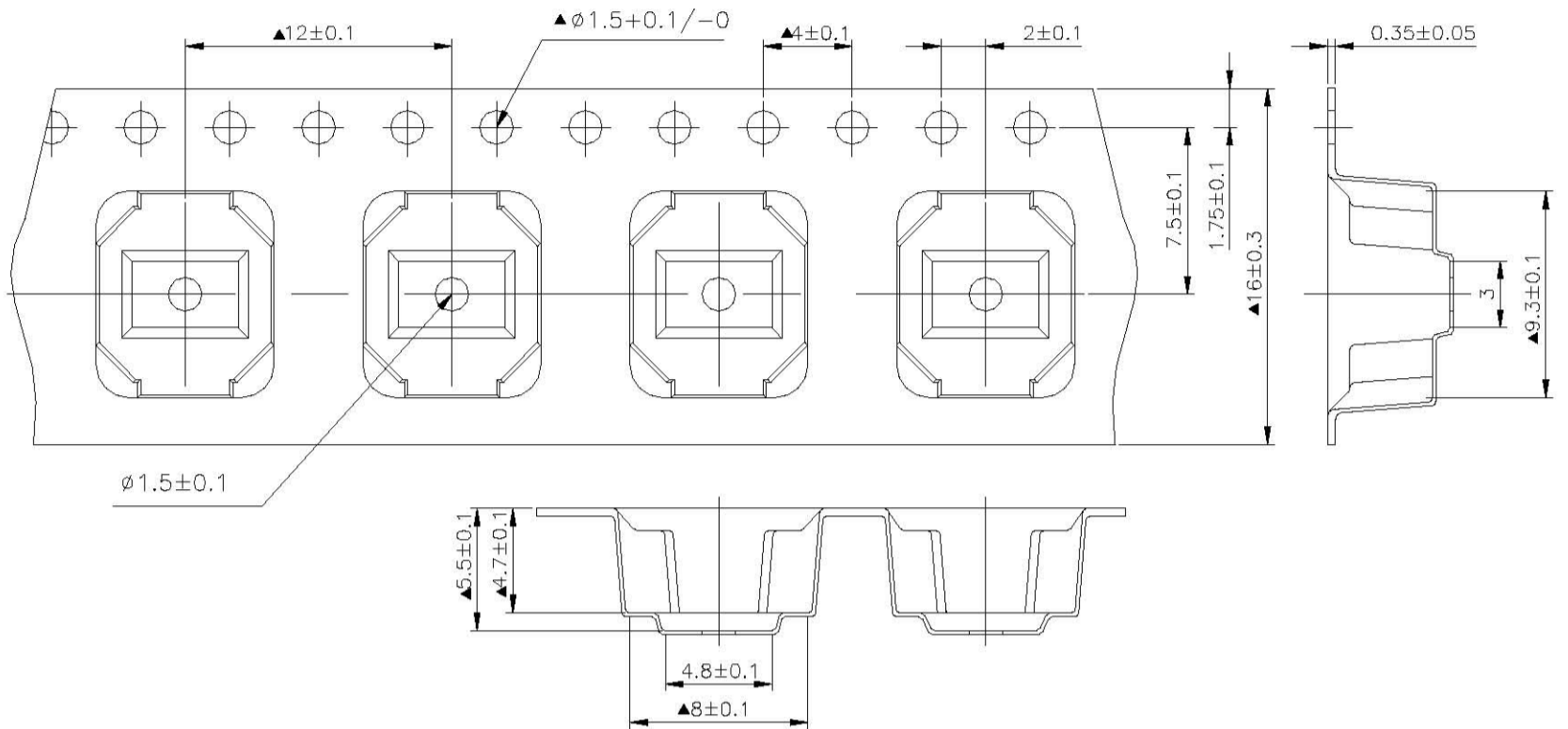

General Tolerance :  $\pm 0.1$ mm

## MT4 REEL

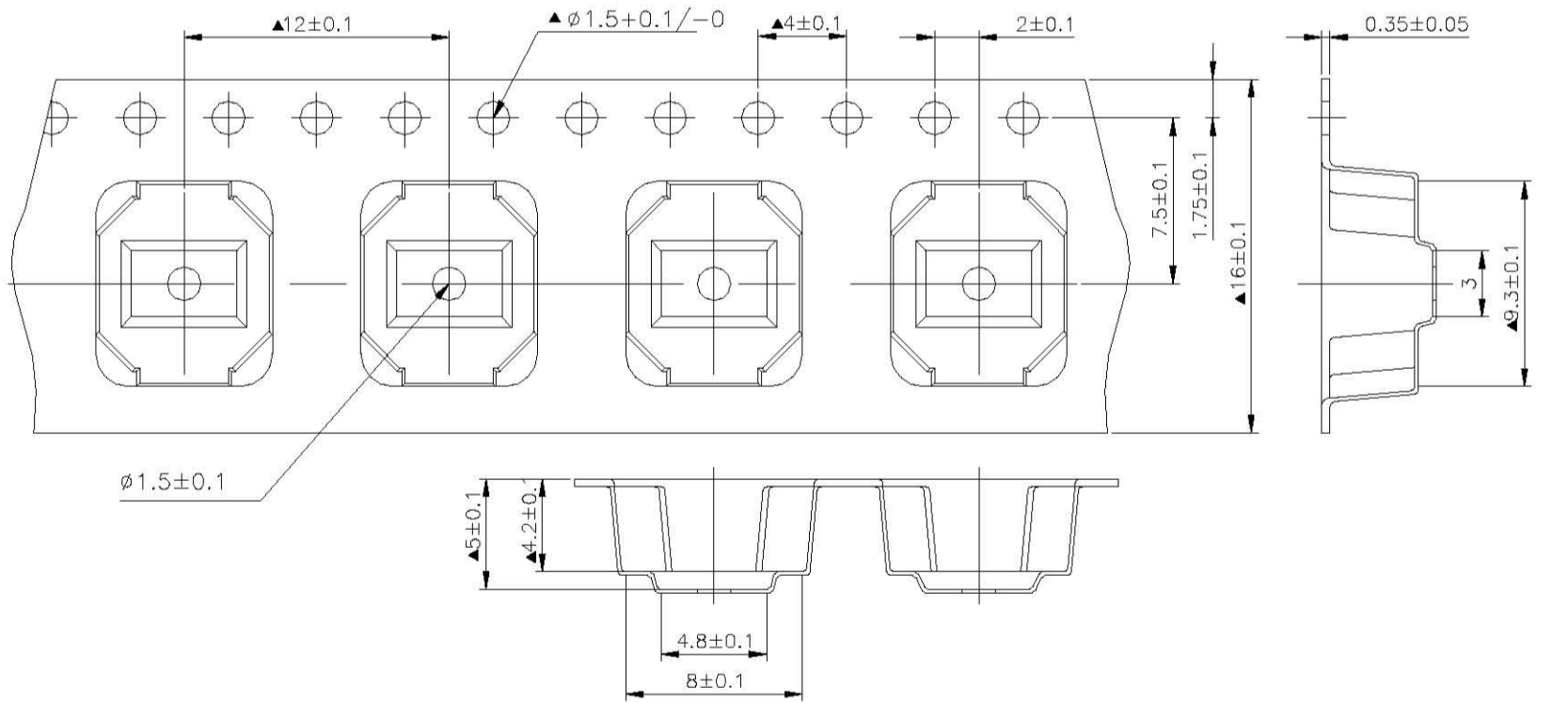

General Tolerance :  $\pm 0.1$ mm